

# DESCRIPTION

## Left view

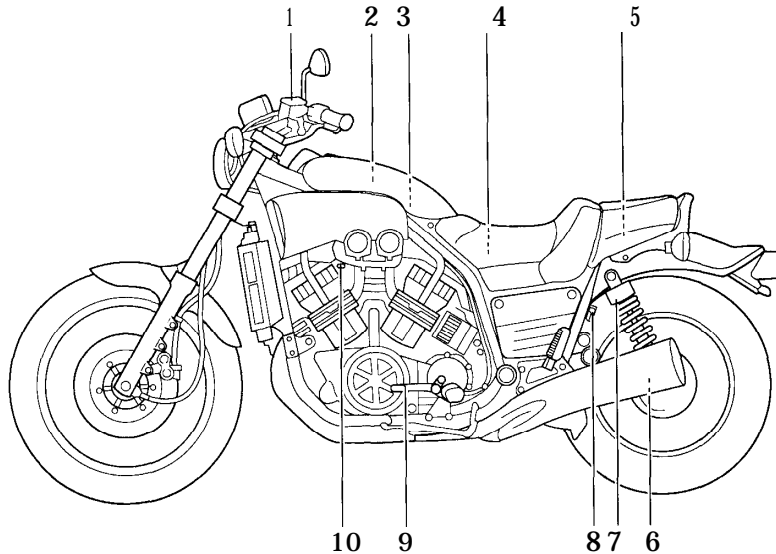

- |  |             |   |             |
|--|-------------|---|-------------|
| 1. Clutch master cylinder reservoir                  | (page 6-29) | 7. Rear shock absorber damping force adjusting knob | (page 3-13) |
| 2. Air filter element                                | (page 6-21) | 8. Helmet holder (page 3-10)                        |             |
| 3. Fuse box  | (page 6-38) | 9. Shift pedal                                      | (page 3-5)  |
| 4. Main fuse box                                     | (page 6-38) | 10. Starter (choke) lever                           | (Page 3-8)  |
| 5. Owner's tool kit                                  | (page 6-1)  |   |             |
| 6. Rear shock absorber spring preload adjusting ring | (page 3-13) |   |             |

## Right view

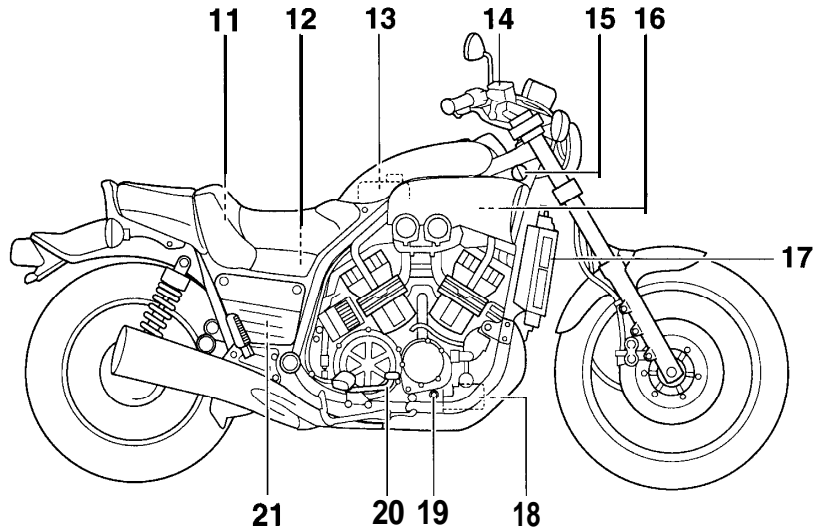

- 11. Fuel tank cap
- 12. Battery
- 13. Coolant reservoir
- 14. Front brake master cylinder reservoir
- 15. Main switch
- 16. Radiator cap
- 17. Radiator
- 18. Engine oil filter cartridge
- 19. Engine oil level check window
- 20. Brake pedal
- 21. Rear brake fluid reservoir

- (page 3-6)
- (page 6-35)
- (page 6-16)
- (page 6-29)
- (page 3-1)
- (page 6-18)
- (page 6-18)
- (page 6-12)
- (page 6-11)
- (page 3-6)
- (page 6-29)

# DESCRIPTION

## Controls and instruments

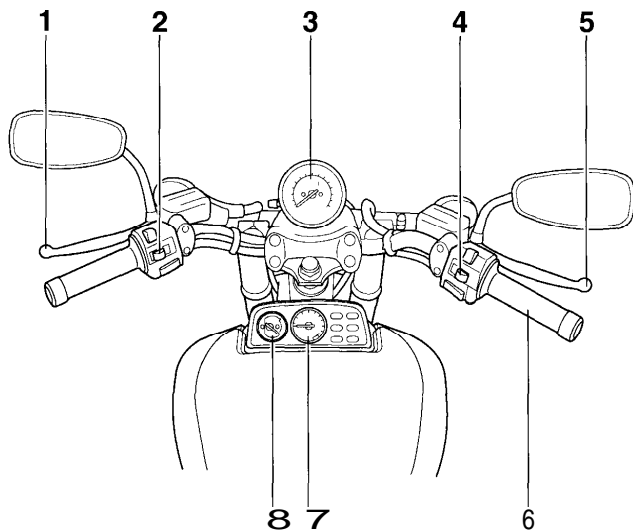

1. Clutch lever
2. Left handlebar switches
3. Speedometer unit
4. Right handlebar switches
5. Brake lever
6. Throttle grip
7. Tachometer
8. Coolant temperature gauge

- (page 3-5)
- (page 3-3)
- (page 3-2)
- (page 3-4)
- (page 3-5)
- (page 6-22)
- (page 3-3)
- (page 3-3)